

# Kit 100. Stereo Preamplifier - Tone Control Unit



This is a preamplifier and tone control unit which will make a useful addition to any of our power amplifier kits. It is extremely easy to construct due to the use of a special IC, the Philips TDA 1524A. This contains all the circuitry required to provide up to 20 dB of voltage gain, +/-15 dB of bass and treble control, channel balance, and a switchable loudness contour.

Because it uses voltage control, linear single gang pots can be used, which lowers the costs and reduces tracking errors. It also allows for control by switches or microprocessor if desired.

## Features

- Simple construction
- Few external components.
- Low noise and distortion.
- Switchable loudness.
- Will drive most power amps.

## Specification

D.C. Input :	15V DC supply or 12V DC battery. 50 mA min.
Maximum output :	> 3 V RMS
Maximum input :	> 300 mV, G = 20 dB > 3V RMS, G = 0dB
Input Z	> 10 k ohm
Output Z	< 300 ohm
Frequency resp. :	< 10 Hz to > 50 kHz +/- 1 dB
THD at 1kHz :	< 0.1 % at 1V output
S/N ratio :	> 80 dB, G = 0 dB
Bass boost/cut	~ 15 dB at 50 Hz
Treble boost/cut	~ 15 dB at 15 kHz

## How it works

All signal processing is done within the TDA1524A by voltage controlled amplifiers and voltage controlled filters. The IC provides a fixed voltage (~ 3.8V DC) at pin 17, and this is used by all the variable resistors to provide an adjustable DC voltage to the appropriate control pins.

Current sensing is used to provide a flat response when R5 is connected to pin 17, and a loudness contour when disconnected.

100 nF capacitors are used on each pot to decouple any AC signals from the control inputs. 10 uF capacitors are used to couple both input and output signals whilst blocking DC. R1 and R2 are to ensure stability with capacitive loads. R3 and R4 are to make sure there is no DC spikes at the output sockets if the load is switched. C3 and C4 control the loudness contour. C5 and C6 are to ensure HF stability.

C15-17 provide power supply filtering. D1 provides protection in case of incorrect supply polarity. The LED is a power on indicator and may be omitted if not required, or preferably mounted on the enclosure. If you are not using a switch pot, you can connect an external switch across the P1 switch pins, or connect a wire link there and switch the power supply.

The power supply is critical to the noise performance of the pre-amp. An on board regulator is provided to reduce mains hum. If you wish to use it with a car or other 12V battery, then you should omit the 7812 regulator, and place a wire link between the regulator input and output pin positions on the PC board. Do not short to earth! This will be necessary because the regulator must have an input voltage at least 2-3V greater than its output, for it to maintain regulation. However a regulator will not be necessary with a battery supply.

If using a plug pack, its output voltage should be 15 to 18V DC. Because most plug packs have poor regulation, one rated at 12V DC will often be around 15V when lightly loaded. The current drain of the pre-amp is less than 50 mA, so many 12 V supplies may be adequate. If you are using a 15-20V supply for your power amplifier, you can use that as your pre-amp supply as well. Make sure you test the voltage first in all cases.

# Kit 100. Stereo Preamplifier - Tone Control Unit

## Construction

First check the RCA sockets to make sure they fit the board. You may need to bend the tags or drill the holes slightly. Do this if necessary, but do not fit the sockets until later. There are five wire links required on the board. Fit these next. Then install the smaller components, starting with the resistors and the IC socket. Do not fit the IC until after you have soldered the socket into place.

You may wish to use pins for the LED connection, if you are going to mount that on the box. You can also use an external switch for the loudness control if you wish. The regulator can be mounted vertically, or bend the leads and bolt it to the board. No heatsink is required. Install the diode and capacitors, leaving the pots and sockets until last.

## Testing

Check the DC supply voltage before connecting to the board. Make sure the volume control is turned down, and that the other pots are centred. Then connect a music source and power amp, and increase the volume slowly. There will be no output at all for a small part of the rotation. This is normal due to the drop out voltage of the IC control. Then you should hear the music. Check the operation of the Bass, Treble and Balance controls, being careful not to use full boost at high volume.

Also check the operation of the Loudness switch being aware that it is level dependent and will have no effect at high volume as it is designed to compensate for changes in the human hearing response at low listening levels. The jumper or switch must be closed to give a flat response.

If there is no output, recheck all wiring, all component positions and polarity of diodes, ecaps, and orientation of the IC's. Check for bad solder joints, and solder bridges between tracks, especially the IC pins. Also check the DC voltage across the pots (IC pins 17 to 18) is between 3.5V and 4V.

The complete data sheet for the Philips TDA1524A can be obtained from our web site at :

[kitsrus.com/projects/tda1524a.pdf](http://kitsrus.com/projects/tda1524a.pdf)

Parts List	
<b>Resistors :</b>	
R1, R2 .....	220R (red red brown)..... 2
R3, R4 .....	4K7 (yellow violet red) ..... 2
R5 .....	2K2 (red red red)..... 1
R6 .....	1K (brown black red) ..... 1
<b>Capacitors :</b>	
C1, 2, 7, 8, 17 .....	10 uF ecap ..... 5
C3, 4 .....	47 nF mylar (473)... 2
C5, 6 .....	15 nF mylar (153)... 2
C9 .....	220 nF poly. (224).. 1
C10 .....	100 uF 25V ecap.... 1
C11, 12, 13, 14, 16 .....	100 nF mono..... 5
C15 .....	1000 uF 35V ecap... 1
<b>Misc. :</b>	
IC1 .....	TDA 1524A..... 1
IC2 .....	LM 7812..... 1
P1 .....	50k linear switch pot... 1
P2, 3, 4 .....	50k linear pot ..... 3
X1, 2, 3, 4 .....	RCA jack..... 4
X5 .....	Power socket ..... 1
D1 .....	Diode 1N4004 ..... 1
L1 .....	Red LED ..... 1
Kit 100 Printed Circuit Board .....	1
18 pin DIL IC socket ... ..	1
3mm screw and nut .....	1
2 pin header and jumper .....	1

# Kit 100. Stereo Preamplifier - Tone Control Unit

## Circuit Diagram

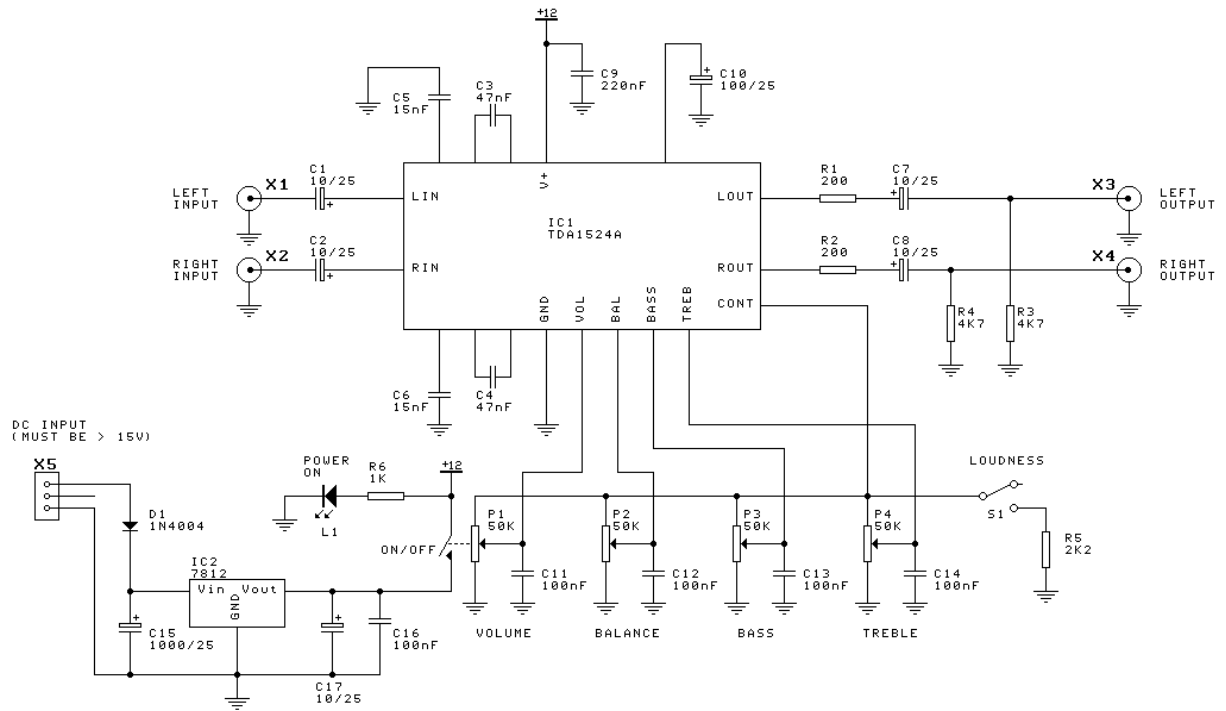

## Photo of completed circuit board

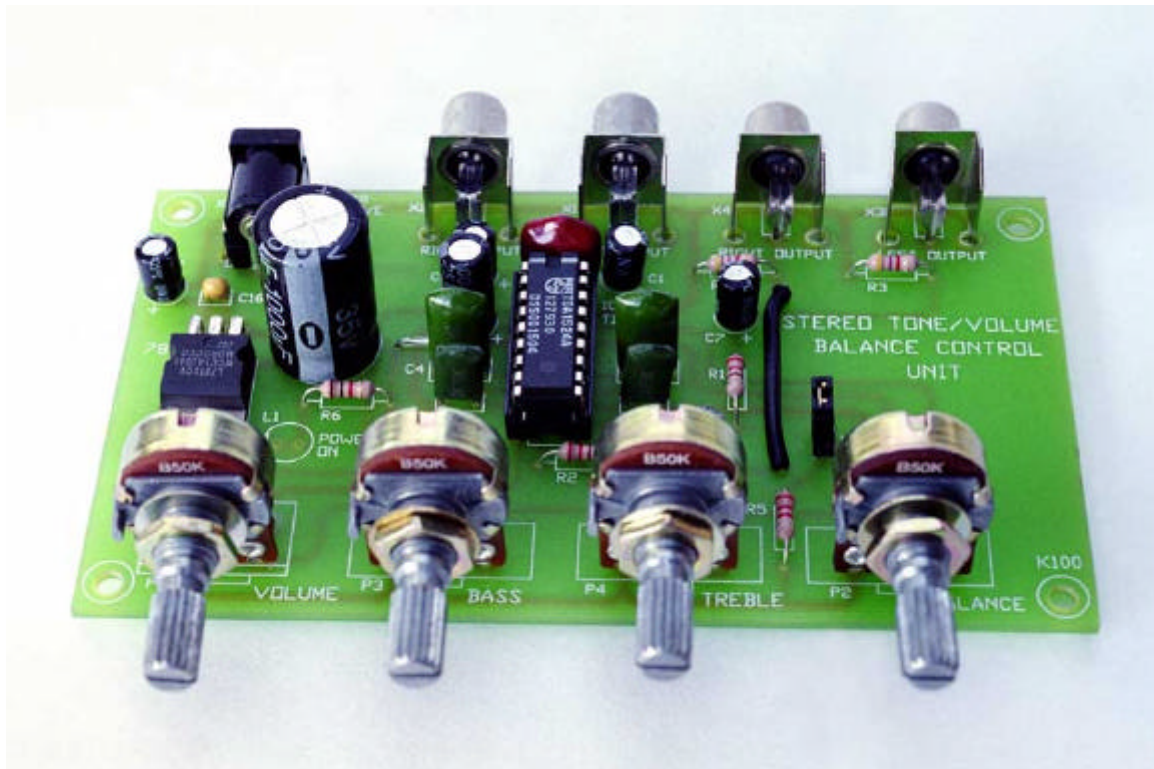

# Kit 100. Stereo Preamplifier - Tone Control Unit

THD at 1 kHz, 1V RMS output.

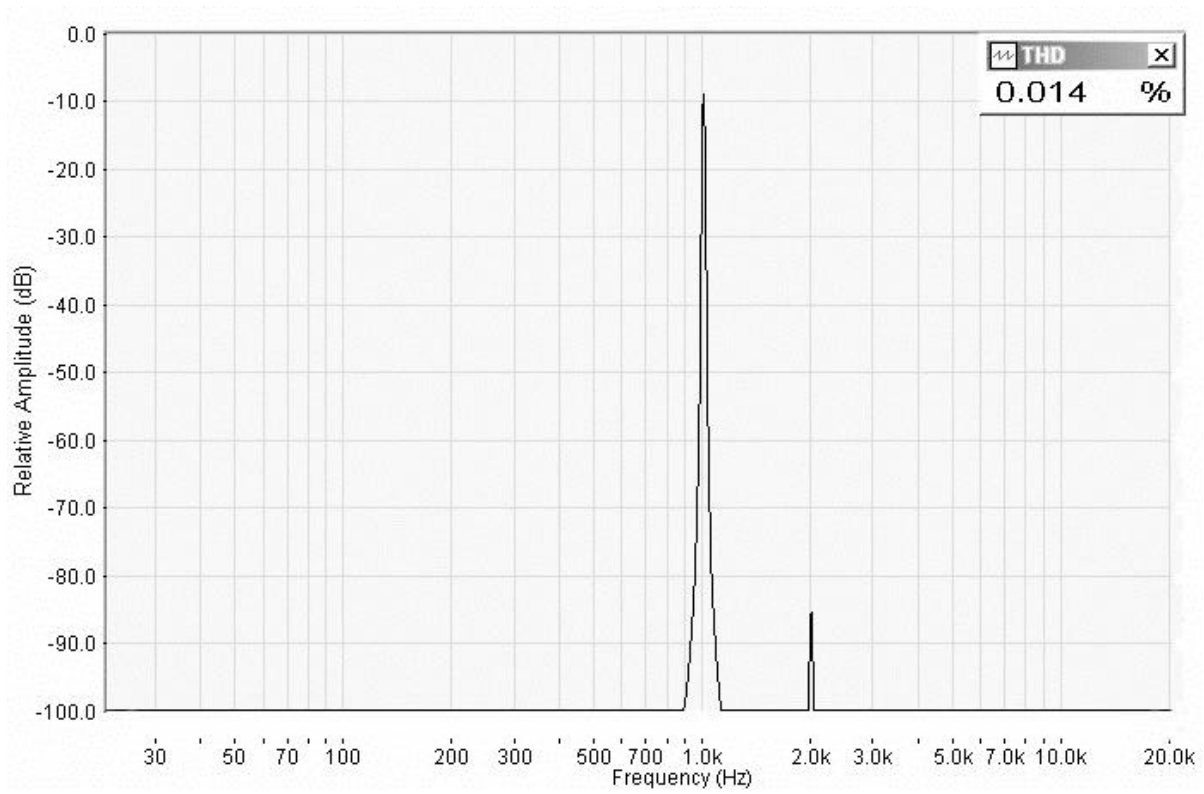

## Effect of Tone Controls Maximum Boost / Cut

